

RULES OF THUMB

1. Place labels on the right edge of the shipment.
2. Avoid the center of the package because the mounting location should be structurally sound.
3. Place labels on the longest side of the package
4. The heavier the shipment, the lower you should mount the label.
5. Place the Alert Sticker on the bill of lading as a reminder for receivers to check the indicator immediately upon arrival.

Recommended Placement

L-30 GREEN - 100G at 50ms (milliseconds) and L-35 ORANGE - 75G at 50ms

PLACEMENT OF LABELS:

Placement is in upper right corner of the package.

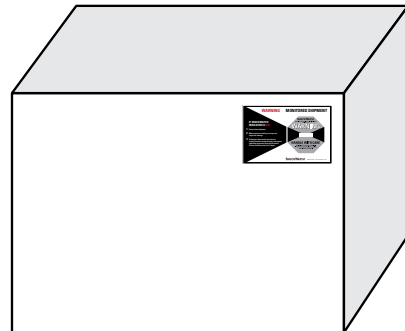

L-47 RED - 50G at 50ms (milliseconds)

PLACEMENT OF LABELS:

- A. For Packages 50 - 100 lbs (22.68 - 45.36 kg)
Placement is in upper right corner of the package.
- B. For Packages 100-500 lbs (45.36 - 226.8 kg)
Placement is along the right edge, at least 24 inches (60.96 cm) from the bottom of the package.

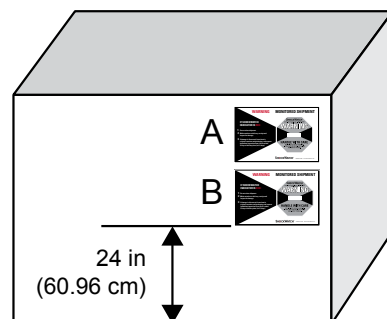

L-55 PURPLE - 37G at 50ms (milliseconds)

PLACEMENT OF LABELS:

A1. For Packages 50 - 100 lbs (22.68 - 45.36 kg)
Placement is in upper right corner of the package. **See Figure A - A1.**

A2. For Packages 100-500 lbs (45.36 - 226.8 kg)
Placement is along the right edge, 12-24 inches (30.48 - 60.96 cm) from the bottom of the package. **See Figure A - A2.**

Figure A

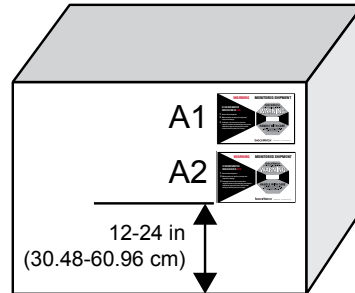

B. If the package is twice as long as it is wide, or palletised shipments use two lab els.

Place a second indicator in the same position on the opposite side of the package. **See Figure B.**

Figure B

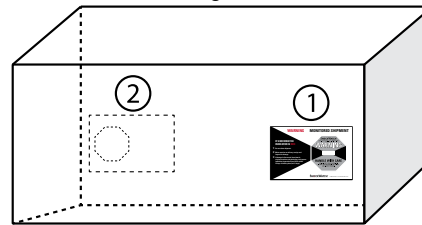

L-65 YELLOW - 25G at 50ms (milliseconds)

PLACEMENT OF LABELS:

A. Place ShockWatch label 12 - 14 in (30.48 - 35.56 cm) from the bottom of the box. Optional: Place a second indicator in the same position on the opposite end of the package.

B. If the package is twice as long as it is wide, or palletised shipments use two ShockWatch labels. Place a second indicator in the same position on the opposite side of the package.

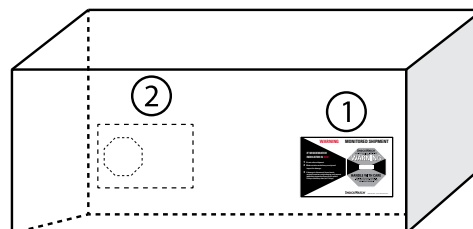
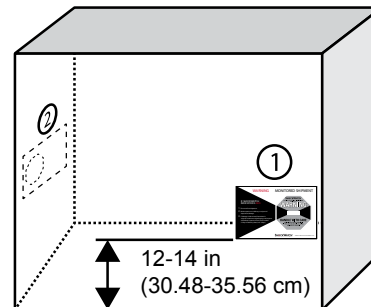

While these instructions are considered best practices, each situation may be different. If you have any questions, please call us on 1300 074 625 or email solutions@shockwatch.com.au