

ShockTrak™ Impact Recording & Tracking System Key Features

The ShockTrak™ Impact Recording & Tracking System combines the ShockLog® 298 Impact Recorder and a satellite communication module to deliver impact recording, real-time reporting and asset location. The system is programmed with parameters optimized for the user's asset.

The ShockTrak System has been developed to monitor shock based on acceleration measurements and impact frequency, then report unacceptable conditions that are potentially damaging. The web-hosted tracking application allows you to view your assets in transit. The ShockTrak System is especially suitable for applications where the cost of exposure to out-of-specification environmental conditions and the need to locate the asset are critical.

When any of the accelerometer signals exceeds the 'wake-up' threshold, the ShockLog processor turns on and checks the sensor outputs at full sampling speed (4096 samples per second per axis). If the output of any sensor exceeds the warning or alarm thresholds, the ShockTrak will record a detailed event. In addition, the detailed time history of the first event to trigger a warning, the first to trigger an alarm and subsequent events will be recorded. Configurations can be set to record 108 events with the highest sampling rate or 870 events at lower sampling rates.

The ShockTrak System has the ability to set alarm conditions on any of the selected data:

- Peak X,Y, Z
- gRMS
- Tilt & Roll
- Internal Temperature

ShockTrak™ System Specifications

System Specification

Operating Temperature Range	-30 to 60°C / -86 to 140°F The unit shall remain operational over the -40 to 85°C / -40 to 185°F range but may experience battery life and RF signal degradation.
Dimensions	320.3 x 239 x 119.1 mm / 12.61 x 9.41 x 4.69 in
Weight	4.4kg / 9.7lbs
Battery	2 x 3.6V AA Lithium (ShockLog) 4 x 1.5V AA Lithium (Satellite Module) 4 x 3.6V C-Sized Lithium (Battery Pack)
Battery Life	Up to 12 months
Case Material	Fiberglass
Sealing	NEMA 1, 3, 4X, 6P, 12
Satellite Technology	Global LEO Satellite operation using the Globalstar Simplex Data Network
ShockTrak Web Hosted Application	Supported on Chrome, IE & Firefox
ShockLog Desktop Software	Functions on Windows XP, Vista, 7, 8, or 10
Communications / Interfaces	Satellite USB 2 iButton
A-D Converter Resolution	12 bits
Flash Memory for Data	4096 kbytes

Data Collection

Event Processor Wake-up Delay	2.5 ms
Timeslot Interval	600 to 3600 seconds
Samples per Channel per Event	512 to 4096
Maximum Number of Events (detailed)	108 to 870
Event Duration	1 to 128 seconds

Accelerometers

Low Frequency Cutoff (-3dB 10g – 100g)	0.1 - 0.5 Hz
High Frequency Cutoff (-3dB)	250 – 300 Hz
Hardware Filters (Programmable)	10 Hz, 40 Hz, 50 Hz, 90 Hz, 120 Hz and 250 Hz
Resolution (% of full scale) 1% for Peaks	0.1%
Scale Factor Accuracy at 5G (event record)	±2%
Additional Error Other Ranges	±2%
Additional Error Peak Capture	±5%
Change of Scale Factor over Temperature	±4%
Acceleration Ranges	±1% to ±200 G
Wake-up Threshold (% of range)	5 to 95%
Warning and Alarm Thresholds (% of range)	5 to 95%

Humidity/Temperature Specifications*

Temperature Measuring Range	-40 to 85° C / -40 to 185° F
Temperature Accuracy	±2° C / ±4° F
Temperature Resolution	0.1° C
Humidity Measuring Range	0 - 100% RH
Humidity Accuracy	±3% RH
Humidity Resolution	0.1% RH
Dew Point Measuring Range	-40°C to 85° C / -40° F to 185° F 0 - 100% RH
Dew Point Relative Accuracy (-20 to 70°C, 25 to 75%RH)	±2° C / ±4° F
Dew Point Resolution	0.1° C

*Temperature and humidity measurements would be recorded inside the ShockTrak enclosure.

Tilt & Roll Specifications

Tilt Range Monitored	±180°
Resolution	0.1°
Transverse Sensitivity	5%

SpotSee Cloud

The cloud based software can be accessed anywhere with a secure login. Chrome, IE and Firefox are supported browsers. Each user has his own secure account access. Data from the ShockTrak is stored in the cloud where journey information such as location of impacts, impacts over time, impact histogram, and temperature are visualized.

ShockLog® Desktop Software

The ShockLog® software runs on a desktop or laptop PC using the Windows XP, Vista, Windows 7, Windows 8, or Windows 10 operating systems.

The software allows the operator to configure the ShockTrak and to extract and examine data records from the instrument.

The software is included in the accessory kit.

Drawings

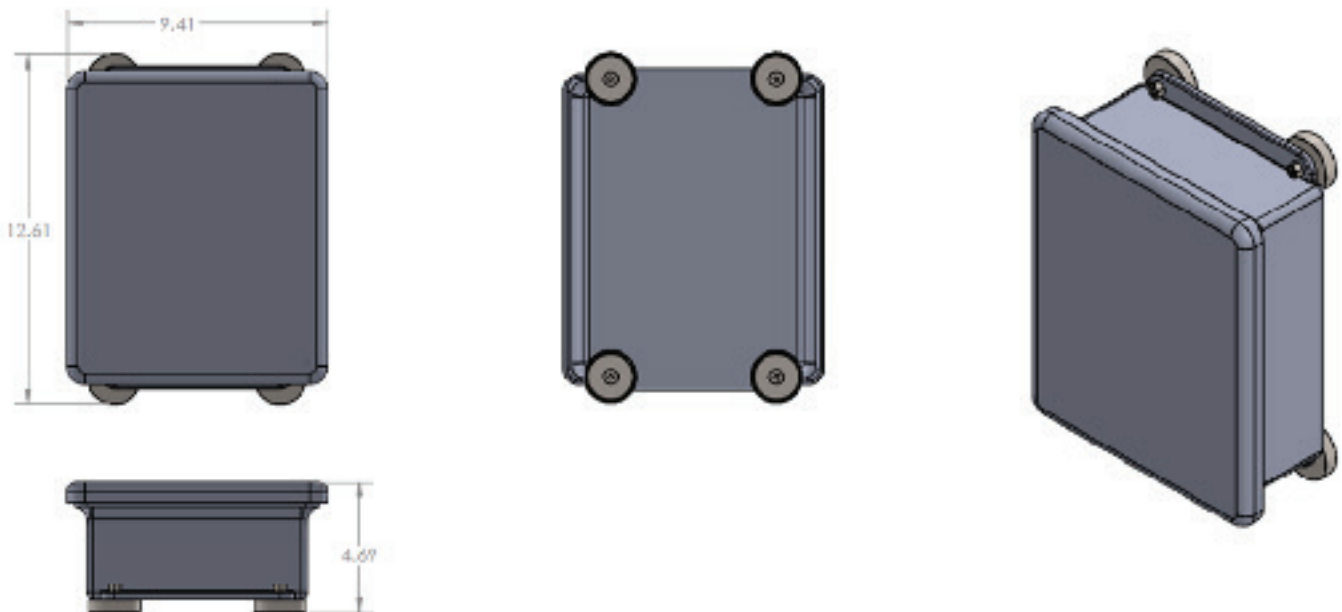

Mounting

IMPORTANT: When mounting the ShockTrak hardware, care must be taken to allow for line of sight to the sky. Failure to do so will result in compromised satellite communication.

It is recommended that you mount the unit prior to starting it. This action prevents any impacts being recorded that are a result of the mounting process.

Find a suitable mounting location on the asset with line of sight to the sky.

The ShockTrak has x, y, and z axes noted on the unit. If the mounting of the ShockTrak does not allow you to match the axes of the unit, it is advisable to make a note of the exact mounting in order to correctly analyze the reported impact values.

The ShockTrak uses magnets for mounting. Grasp the unit in the positions noted by “Hold Here.” Position two magnets in place and then carefully roll the last two magnets into position.

Magnetic mounts are intended for temporary mounting.

SAFETY WARNING



MAGNETIC FIELDS PRESENT

The mounting plate described in these instructions has a magnetic field. Do not locate near pacemakers or other equipment that is sensitive to magnets.

PINCH HAZARD

Mounting ShockTrak may cause injury to hands. Exercise caution to avoid pinching hands and fingers when installing the mounting unit.

Accessories & Related Products

Batteries are included with each ShockTrak unit. Saft batteries are recommended. Due to lithium battery flight restrictions, SpotSee recommends that replacement batteries be sourced locally by the ShockTrak user.

New users of the ShockTrak must purchase an accessory kit which includes the desktop software – needed for programming the ShockTrak unit, post journey analytics and full data set downloading. The kit contains the following items (USB drive with desktop software; ShockLog Quick Start Guide; USB Communication Cable; iButton Set: start, stop, download, setup, and clock; USB Connection bus and cable). Additional software licenses, iButtons, and cables may be ordered separately.

Ordering Information

Part Number	Product Description
40600K	ShockTrak Impact Recording & Tracking System – includes 6 month connectivity contract.
40615	6 month connectivity / access renewal contract
SL KIT 298-248-A	ShockLog Accessory Kit – Required for first system
OPTIONAL PRECONFIGURATIONS*:	
40650	Configuration 1 – Asset weight 136 – 226 Tonne. XYZ + temp recording. 3 month journey
40651	Configuration 2 – Asset weight 45 – 136 Tonne XYZ + temp recording. 3 month journey
40652	Configuration 3 – Asset weight 27 – 45 Tonne. XYZ + temp recording. 3 month journey

* Preconfiguration applies to device's first journey. Reuse of the device requires reprogramming.