



the smart way to measure time & temperature

Product Specification

Timestrip® 1 Month RT BOT TS-201



General:

Each Timestrip® indicator is a small, self-adhesive label that can be attached to or integrated into a product, package or carrying card*. It monitors elapsed time and indicates when key time markers and a pre-defined elapsed time have been reached. The indication of elapsed time is irreversible. (*see adhesive specification in Appendix 1 below for further details.) Indicators can be made for many different temperature environments, but each product is calibrated for use in a specific temperature environment.

Timestrip® 1 month is calibrated for use at room temperature. Using this product in other temperature environments may affect its performance.

How to use:

Timestrip® indicators are completely inert prior to activation and can be stored at room temperature.

To activate fully squeeze the button and within 2 minutes a red activation line will appear. If not, immediately re-squeeze the button fully. When the activation line appears, the indicator is armed and ready to use. The red dye will continue to progress until the maximum elapsed time has been reached.

I) Performance Specifications:

- Run-Time: 1 month (30 days)
- Calibration temperature: 22°C ± 1°C
- Accuracy: ± 15 % in time under isothermal conditions
- Progress Isotherms: See Fig. 1
- *Activation Force: 5 ± 2 kgf

* Activation is applied by firmly squeezing the button (Incase the activation line doesn't appear within 2 minutes re-squeeze the button).

II) Product Specification:

- Button Position: Button on Top Layer (BOT)
- Colour of Progressing Front: Red
- Adhesive: 2641 Finger-lift 36/30 mm
- Graphics: See Fig. 2
- Product drawing: See Fig. 3
- Usage: The usage of the product in any assembly or production line must be agreed upon in advance, as it may alter performance specifications.

III) Product Construction:

The indicator is constructed of a polymeric assembly multilayer and aluminium-plastic laminate. It encapsulates coloured oils.

* All materials are non-toxic.

IV) Packaging & Presentation:

Bag of 500 units

V) Storage Conditions (un-activated):

- Store in cool dark environment
- Recommended: 22°C/72°F at 20-80% RH
- Please note that before activation, the product can tolerate short term exposure during transit (hours or a few days) to temperatures in the range -30°C to +55°C. However, long term storage should be under recommended conditions.

VI) Shelf-life:

- 3 Years from date of manufacture (MD). The MD is stated on each pack.

visit www.timestrip.com

Fig 1: Progress Isotherm

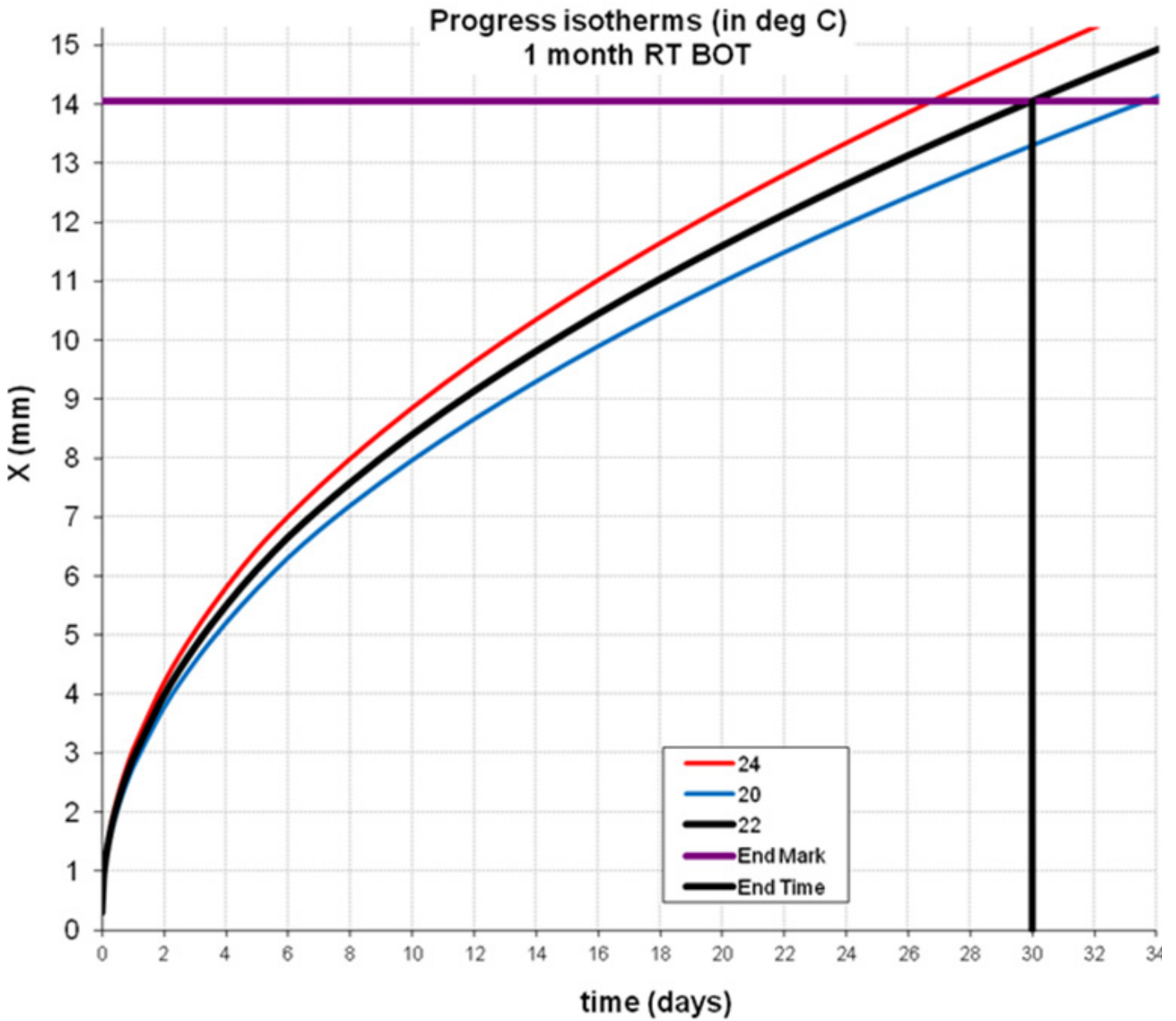

Fig 2: Product Drawing

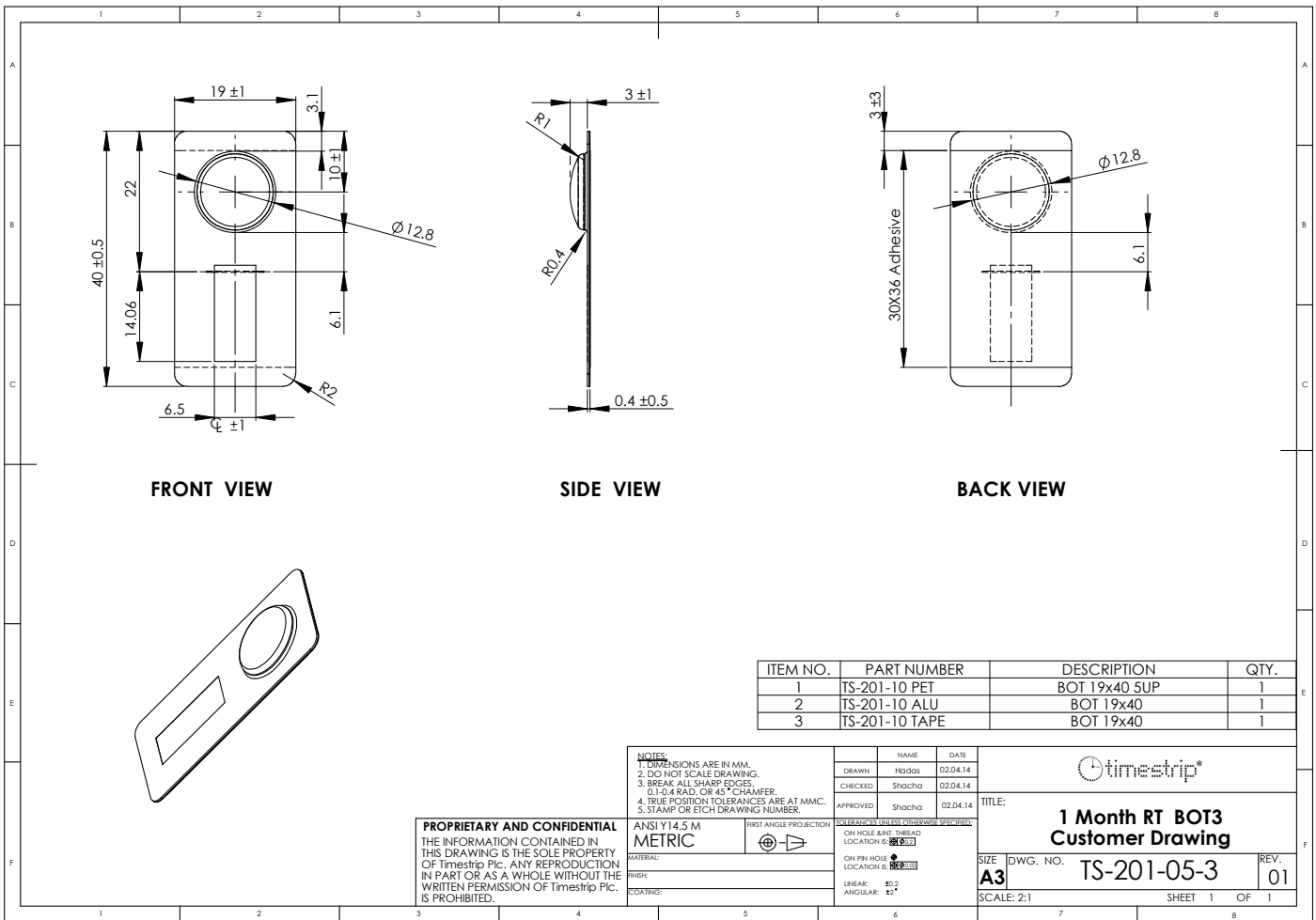
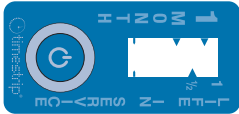
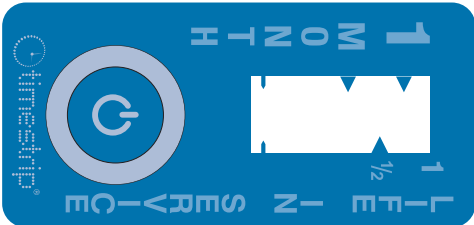

Fig 3: Graphics



100%



200%

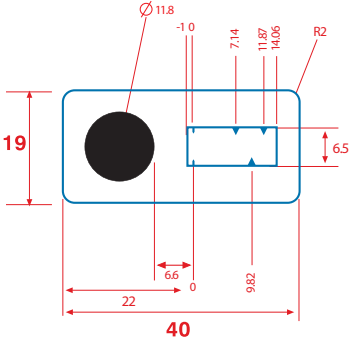

- 50% 100c 30m 0y 20k
- 100c 30m 0y 20k
- p536cvc

***For Approval:**

1. Print out, sign and Fax to +972-9-8991347
- or
2. Send a Mail with the approved graphics attached to mail.

Customer approval *			
Name		Title: 1 Month RT BOT	
Sign.		Graphic no. 800-201B	
Date		Rev. 2 SH. 1 OF. 1	
		Graphic Designer: Hadas 01.04.14	
		Ln. Tolerance: ±0.5mm.	
		Drawing No.:	
		Printing DWG:	



the smart way to measure time & temperature

Appendix 1

Pressure Sensitive Adhesive Data

Timestrip Adhesive - Product # 2641

	<u>SUBSTANCE</u>		<u>THICKNESS</u>
Adhesive	40gsm		
Tissue	12gsm	Adhesive & Carrier	95 micron
Adhesive	45gsm		
Liner	80gsm	Liner	70 micron

PRODUCT DESCRIPTION

A permanent tape with a tissue carrier. The adhesive is a modified acrylic, offering good UV light and chemical resistance together with high performance especially to difficult surfaces. The liner is a two side release system.

APPLICATIONS

The high tack/adhesion of 2641 makes it especially useful for applications involving the bonding of difficult substrates such as many foams, rubbers and polythene type materials. The product is also useful for various mounting applications.

ADHESIVE PROPERTIES

		<u>20 min</u>	<u>24 hour</u>	<u>TEST METHOD</u>
Adhesion to steel	open side	1300 N/M	1400 N/M	BS7116:1990 - D
	closed side	1300 N/M	1400 N/M	BS7116:1990 - D
Shear Adhesion	open side	5 hours		BS7116:1990 - B
	closed side	5 hours		BS7116:1990 - B
Release of liner from adhesive		10 N/M		BS7116:1990 - E

THERMAL PROPERTIES

Recommended service temperature range	-40°C to 110°C	-40°F to 230°F
Application temperature range	5°C to 60°C	41°F to 140°F

SHELF LIFE

Minimum shelf life when stored in closed cartons away from direct sources of heat and sunlight. 2 Years

HEALTH AND SAFETY INFORMATION

The adhesive conforms to F&DA Regulation 175.105.

Note

Values given are average and should not be taken as a maximum or minimum for specification purposes. Specific technical details, applications information and suggested uses available.

Document information

Document Type	Identifying No.	Rev./Issue	Date
Graphics	800-201B	02	01.04.14
Product Drawing	TS-201-5-3	01	02.04.14
Adhesive #2641 Data Sheet	QA-AD1	00	12/2009
Product Specification Sheet	--	02	04.09.14

visit www.timestrip.com