

Product Specification

Timestrip® 1 Hour Room temperature

Button On Top

TS-310

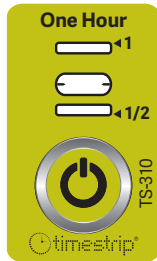

General:

Each Timestrip® indicator is a small, self-adhesive label that can be attached to or integrated into a product, package or carrying card* (*see adhesive specification in Appendix 1 below for further details). It monitors elapsed time and indicates when key time markers and a pre-defined elapsed time have been reached. The indication of elapsed time is irreversible. Indicators can be made for many different temperature environments, but each product is calibrated for use in a specific temperature environment.

Timestrip® 1 hour is calibrated for use at room temperature. Using this product in other temperature environments may affect its performance.

How to use:

Timestrip® indicators are completely inert prior to activation and can be stored at room temperature.

To activate fully squeeze the button and within 2 minutes the word ON will appear. If not, immediately re-squeeze the button fully. When ON appears, the indicator is armed and ready to use. The blue dye will continue to progress until the maximum elapsed time has been reached.

I) Performance Specifications:

- Run-Time: 1 Hour
- Calibration temperature: 22 °C ± 1 °C

- Accuracy: ± 15 % in time under isothermal conditions

- Progress Isotherms: See Fig. 1

- *Activation Force: 5 ± 2 kgf

* Activation is applied by firmly squeezing the blister (In case the word ON doesn't appear within 2 minutes re-squeeze the blister).

II) Product Specification:

- Button Position: Button on Top Layer (BOT)
- Colour of Progressing Front: Blue
- Adhesive: #2641, Pressure sensitive, -40 °C to +110 °C, Finger lift –See Appendix 1
- Graphics: See Fig. 2
- Product drawing: See Fig. 3
- Usage: The usage of the product in any assembly or production line must be agreed upon in advance, as it may alter performance specifications.

III) Product Construction:

The indicator is constructed of a polymeric assembly multilayer and aluminium-plastic laminate. It encapsulates coloured oils.

* All materials are non-toxic, latex, silicon and PVC free.

IV) Packaging & Presentation:

Bag of 500 units

V) Storage Conditions (un-activated):

- Store in cool dark environment
- Recommended: 22 °C/72 °F at 20-80% RH
- Please note that before activation, the product can tolerate short term exposure during transit (hours or a few days) to temperatures in the range -30 °C to +55 °C. However, long term storage should be under recommended conditions.

VI) Shelf-life:

- 2 Years from date of manufacture (MD). The MD is stated on each pack.

Fig 1: Progress Isotherm

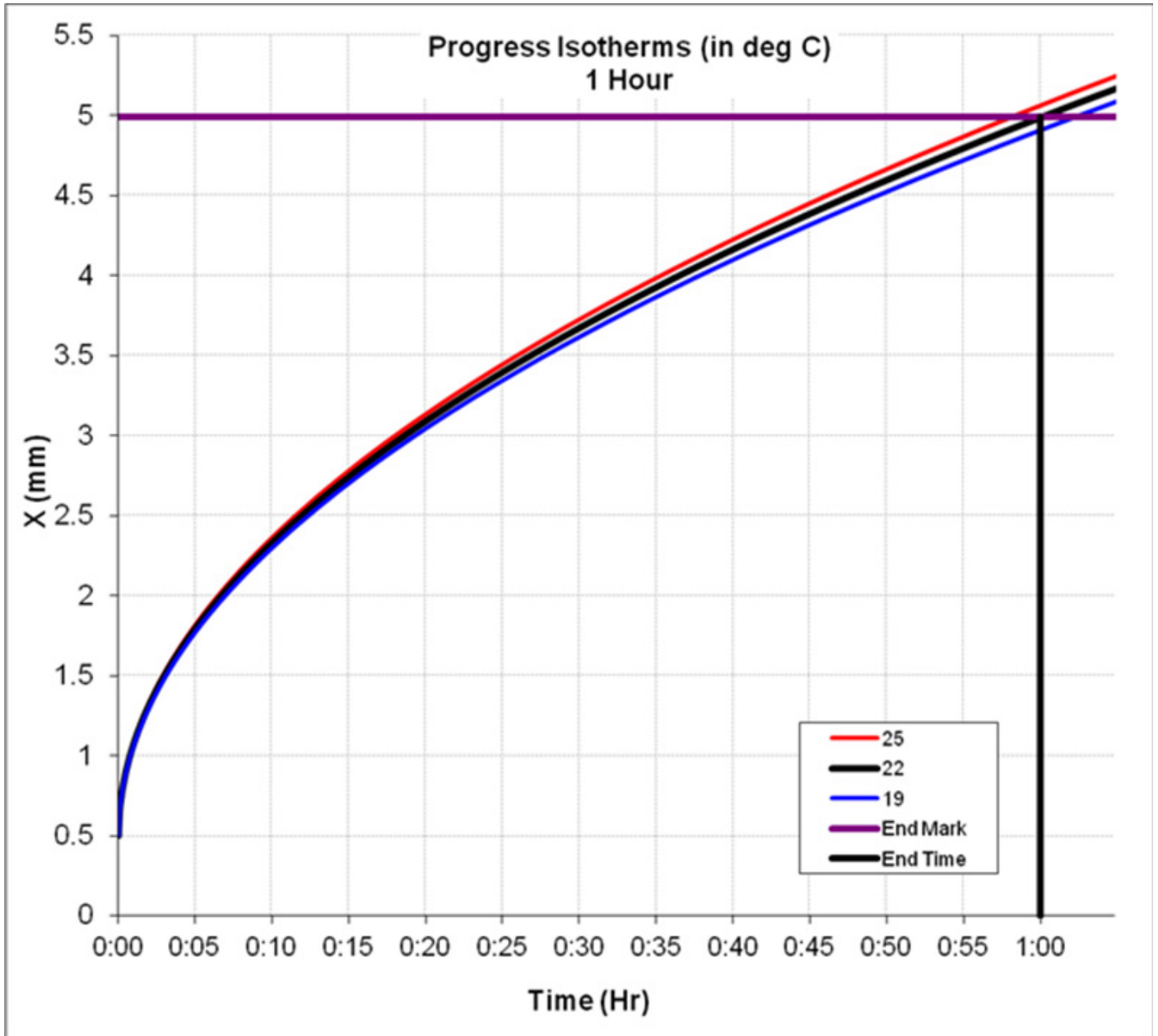

Fig 2: Product Drawing

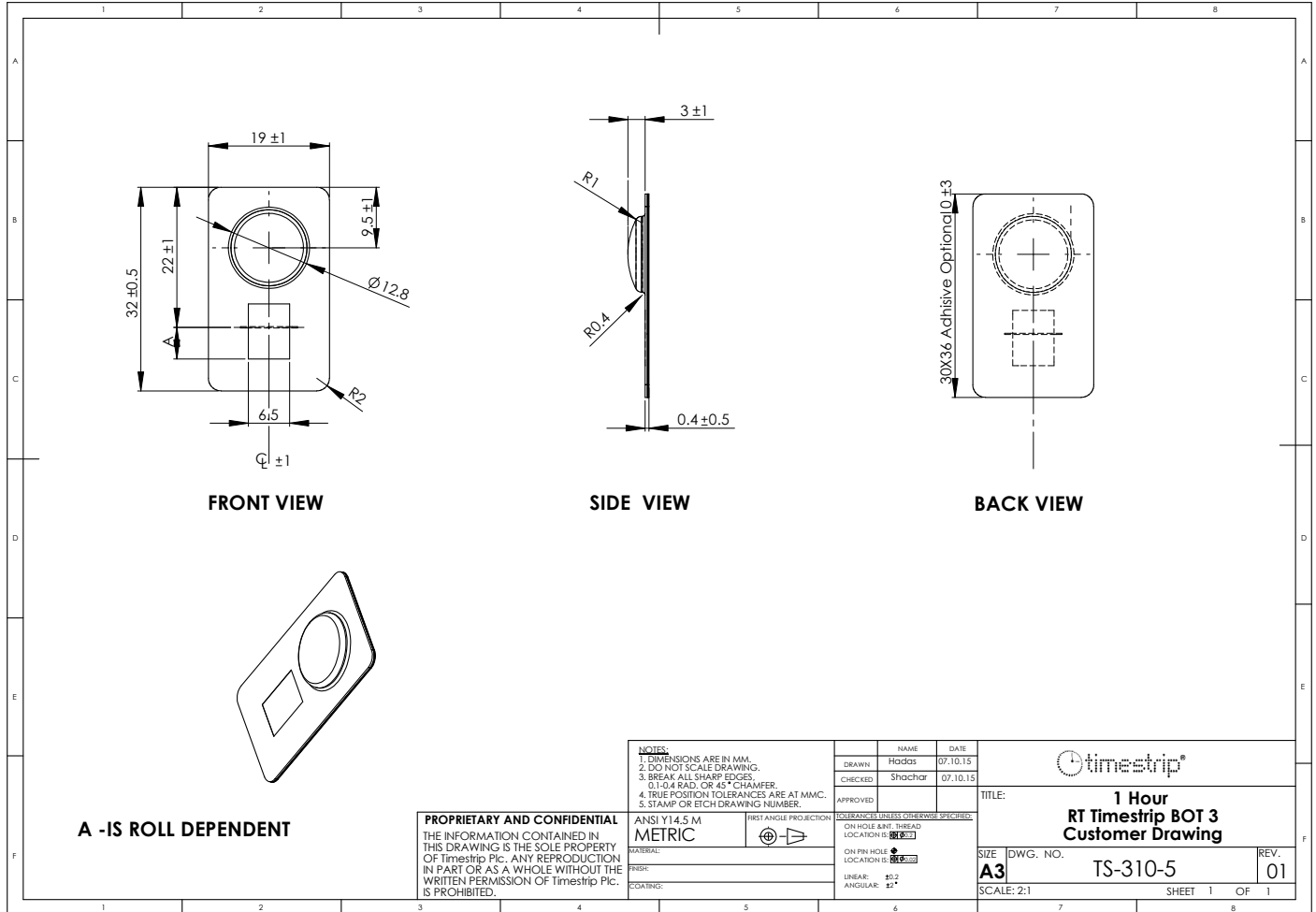
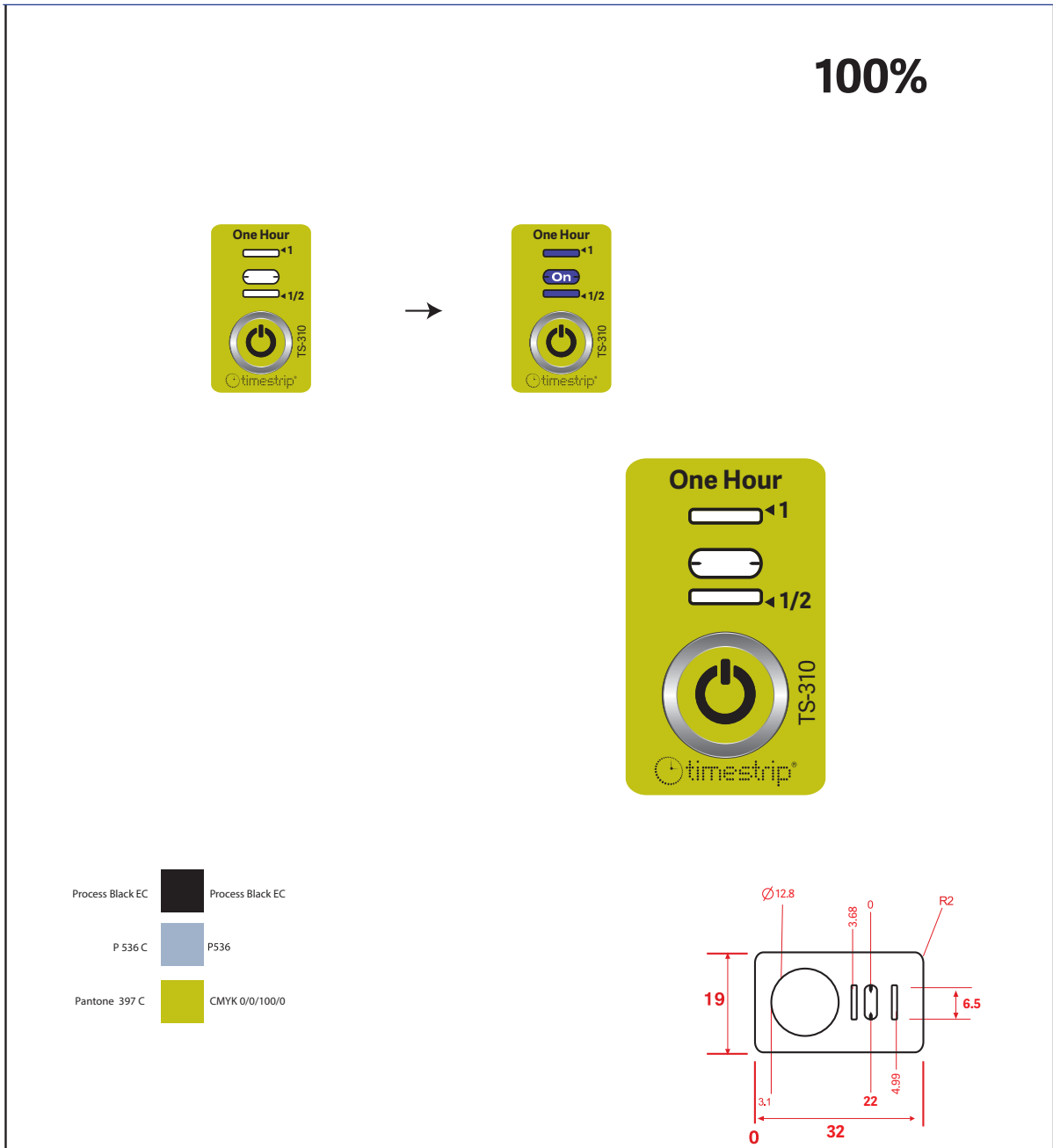



Fig 3: Graphics



Process Black EC Process Black EC
 P 536 C P536
 Pantone 397 C CMYK 0/0/100/0

*For Approval:

1. Print out, sign and Fax to +972-9-8991347 or
2. Send a Mail with the approved graphics attached to mail.

		Title: 1 Hour RT BOT	
Name		Graphic Designer: Hadas 07.10.15	Graphic no. 800-310
Sign.		LIn. Tolerance: ±0.5mm.	Rev. 07
Date		Drawing No.:	SH. 1 OF. 1
		Printing DWG:	



the smart way to measure time & temperature

Appendix 1

Pressure Sensitive Adhesive Data				
Timestrip Adhesive - Product # 2641				
	<u>SUBSTANCE</u>			<u>THICKNESS</u>
Adhesive	40gsm			
Tissue	12gsm	Adhesive & Carrier		95 micron
Adhesive	45gsm			
Liner	80gsm	Liner		70 micron
<u>PRODUCT DESCRIPTION</u>				
A permanent tape with a tissue carrier. The adhesive is a modified acrylic, offering good UV light and chemical resistance together with high performance especially to difficult surfaces. The liner is a two side release system.				
<u>APPLICATIONS</u>				
The high tack/adhesion of 2641 makes it especially useful for applications involving the bonding of difficult substrates such as many foams, rubbers and polythene type materials. The product is also useful for various mounting applications.				
<u>ADHESIVE PROPERTIES</u>		<u>20 min</u>	<u>24 hour</u>	<u>TEST METHOD</u>
Adhesion to steel	open side	1300 N/M	1400 N/M	BS7116:1990 - D
	closed side	1300 N/M	1400 N/M	BS7116:1990 - D
Shear Adhesion	open side	5 hours		BS7116:1990 - B
	closed side	5 hours		BS7116:1990 - B
Release of liner from adhesive		10 N/M		BS7116:1990 - E
<u>THERMAL PROPERTIES</u>				
Recommended service temperature range			-40°C to 110°C	-40°F to 230°F
Application temperature range			5°C to 60°C	41°F to 140°F
<u>SHELF LIFE</u>				
Minimum shelf life when stored in closed cartons away from direct sources of heat and sunlight.			2 Years	
<u>HEALTH AND SAFETY INFORMATION</u>				
The adhesive conforms to F&DA Regulation 175.105.				
Note				
Values given are average and should not be taken as a maximum or minimum for specification purposes. Specific technical details, applications information and suggested uses available.				
For additional information contact us on:				
1, Haatzmut Street, P.O. box 3005, Even Yehuda, 40500, Israel Tel: +972-9-8992005 Fax: +972-9-8991347				
QA-AD1 12/09				

Document information

Document Type	Identifying No.	Rev./Issue	Date
Graphics	800-310	07	07.10.15
Product Drawing	TS-310-5	01	07.10.15
Adhesive #2641 Data Sheet	QA-AD1	00	12/2009
Product Specification Sheet	--	00	07.10.15

visit www.timestrip.com