

Best Practices for Mounting

Mount the ShockLog close to the most sensitive part of the product being monitored. The ShockLog should be mounted to a solid, rigid surface and as low as possible. When monitoring long shipments (>20 feet / 6 meters), it is best to mount a ShockLog at both ends of the shipment.

For best results, it is recommended that the unit be mounted directly to the product being monitored using all four mounting bolts included with the ShockLog, as shown in the figure below.

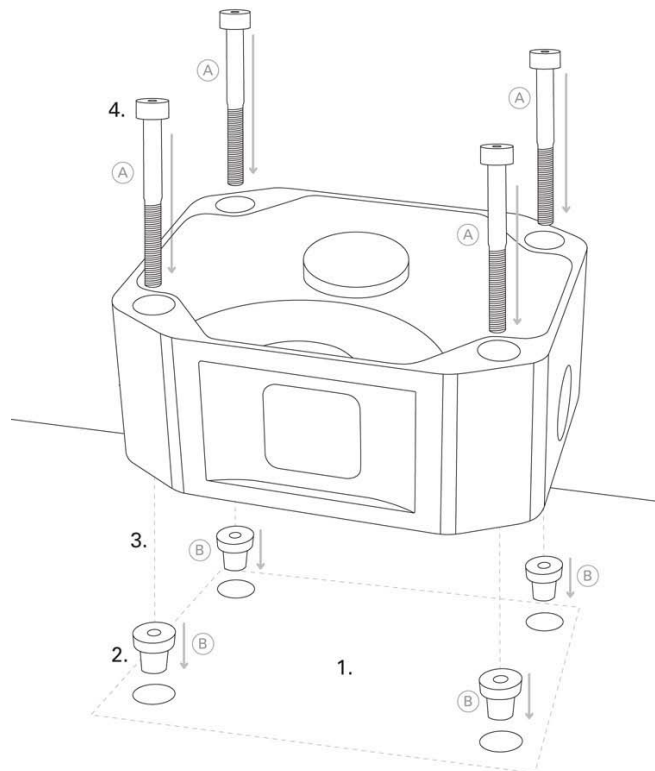

Kit contains:

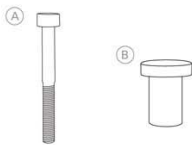

(A) 4 x M5x45 bolts

(C) 4 x black rubber anti-vibration isolation bushings

You will need:

- Electric drill with drill bit between 10.2mm and 10.3mm in diameter
- 5mm allen key

Instructions:

1. Drill 4 (four) \varnothing 10.2mm-10.3mm holes in your product to a depth of at least 17mm. Alternatively a mounting plate with the four holes could be mounted to your product.
2. Insert the 4 isolation bushings in the 4 holes, narrow end first.
3. With the ShockLog facing up align bolts with anti-vibration bushings.
4. Push M5 bolts through the holes from front to back. Tighten bolts clockwise with the allen key. Begin with 2 bolts diagonally opposite each other for optimal grip.

If it is not possible to mount the ShockLog with mounting bolts, it is possible to use an aggressive adhesive or double-sided tape; however, it is important to remember that the ShockLog should not be free to move inside the shipment.

Additionally, a magnetic mounting plate is available that have been predrilled for the four rubber bushings provided in the mounting kit. See the Drawings section for plate dimensions.

Avoid building special brackets to mount the ShockLog. If a cover is required over the product being monitored, place the cover over the ShockLog, but do not attach the unit to the cover.

The ShockLog assumes the axes indicated on the unit. Mount the ShockLog either vertically or horizontally and note the orientation to assist with data analysis.

Drawings

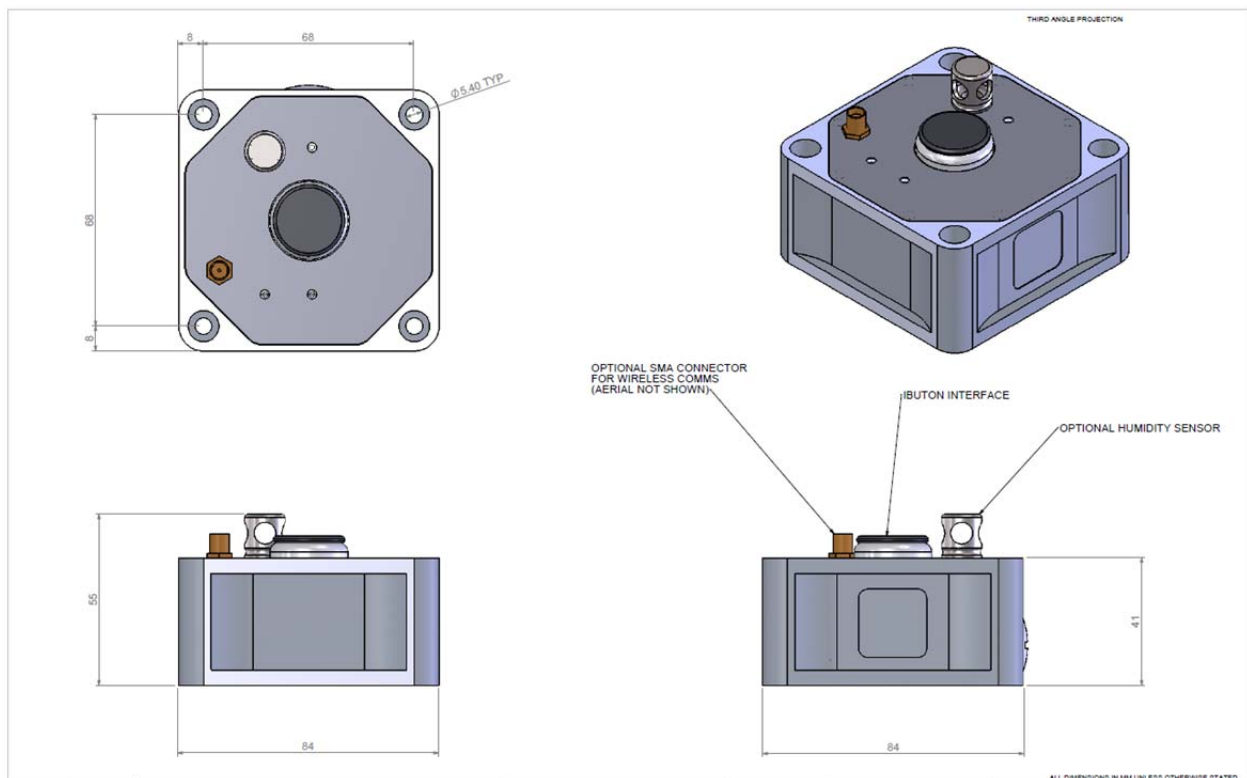

Magnetic Mounting Plate

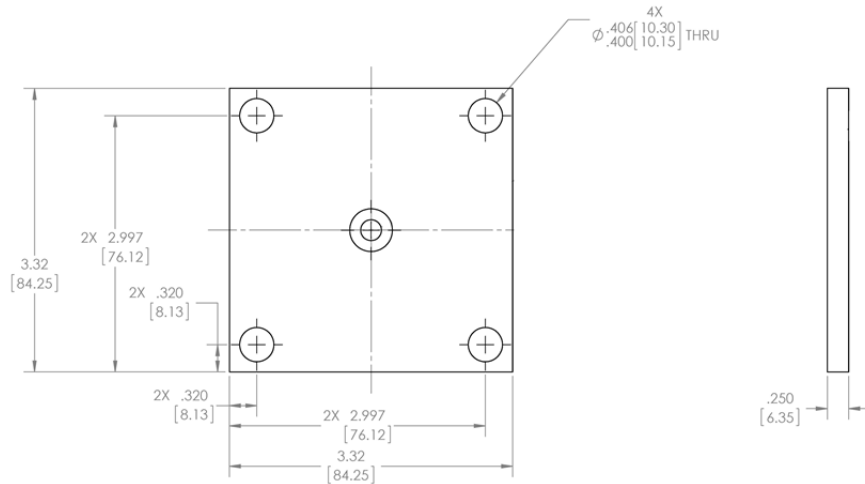

Note: Dimensions in inches

Accessories & Related Products

Batteries, a mounting kit and a companion label are included with each ShockLog 208. New users of the ShockLog 208 will be required to purchase a kit in order to get all the necessary accessories and software licenses to correctly operate the device. The kit contains the following items (CD containing software and manual; Quick Start User Manual; USB Communication Cable; and 2 AA Lithium Batteries). iButtons, additional software licenses, and cables can be ordered separately.

The optional Humidity/Temperature Sensor (built-in) can be ordered to extend the conditions monitored by the ShockLog.

Declaration of Conformity

This ShockLog product is in compliance with the essential requirements and other relevant provisions of directives, ESTI EN 301 489, EN 61326, FCC Rules CFR47 Parts 15 and RTCA/DO160D. Copies of these Declarations of Conformity are available upon request.